

**MOTOR SPECIFICATION SHEET**

MODEL : CNHM05-6080-11 (LT) (Motor model : SF-JRG 1/2HP 4P)

USED FOR : GEAR MOTOR

DESCRIPTION	DETAIL				
PHASE	3				
MODEL NAME	CNHM05-6080-11				
RATED OUTPUT, HP (kW)	1/2 (0.4)				
POLE	4				
CODE	MEATH CODE : 1G1011-005N60801				
OUTLINE DRAWING NO.	OMM74O965-*				
RATED VOLTAGE (V)	220	380	415	220	440
RATED FREQUENCY (Hz)	50	50	50	60	60
RATED CURRENT (A)	2.00	1.15	1.20	1.80	1.00
RATED SPEED (min <sup>-1</sup> ) *	128	128	130	155	157
THERMAL CLASS	155(F)				
RATING	S1 (CONTINUOUS)				
ENCLOSURE CONSTRUCTION	TOTALLY ENCLOSED FAN COOLED				
DEGREES OF PROTECTION	IP55				
METHOD OF COOLING	IC411				
FRAME NO.	71M				
WEIGHT (kg)	12				
STANDARD	IEC 60034-1, JEC-2137-2000				
INSTALLATION	FOOT MOUNTED				
ROTATION	CCW (VIEWED FROM SHAFT END)				
BEARING	LOAD SIDE : 6202ZZ OPPOSITE SIDE : 6201ZZ				
BEARING GREASE	UREA GREASE				
CIRCUMSTANCE	AMBIENT TEMPERATURE : -20 ~ +40°C				
CONDITION	AMBIENT HUMIDITY : 95%RH OR LESS ABOVE SEA LEVEL : 1000m OR LESS ENVIRONMENT : NO BURSTING/EROSIVE GAS OR VAPOR				
COLOR	MUNSELL N5.5 (GRAY)				
TERMINAL BOX	NO. OF LEAD WIRES : 6 SOURCE CONNECTION : TERMINAL BLOCK				
INSULATION RESISTANCE	BY DC 500V MEGGER - ≥100MΩ				
DIELECTRIC TEST	AC 50Hz 1800V - 1min. (Based on rated voltage 380V)				
GEAR RATIO	1 : 11				
GEAR LUBRICANT	GREASE (Filled from factory.)				
SERVICE FACTOR	1.48				
MATERIAL	FRAME : STEEL PLATE BRACKET (GEAR SIDE) : CAST IRON BRACKET (OPP SIDE) : STEEL PLATE GEAR CASE : ALUMINIUM SHAFT (MOTOR) : STEEL SHAFT (GEAR OUTPUT) : STEEL STATOR CORE : ELECTRICAL STEEL WIRE : ENAMELLED COPPER MAGNET WIRE INSULATOR : POLYESTER FILM VARNISH : EPOXY DENATURALIZATION POLYESTER ROTOR CORE : ELECTRICAL STEEL CONDUCTOR : ALUMINIUM TERMINAL BOX : STEEL PLATE PAINTING : POLYURETHANE RESIN				
PRODUCTION COUNTRY	THAILAND				

\* This value is calculated by MOTOR RATED SPEED / GEAR RATIO.

( Catalog value is specified by follow Gear maker specification, 50/60Hz = 132/159min<sup>-1</sup>. )

Specifications subject to change without notice.

<b>SPECIFICATION SHEET NO.</b>				
SS-M-7366-A				

**MODEL CNHM THREE PHASE INDUCTION MOTOR OUTLINE DRAWING**

**GEAR MOTOR**  
**TOTALLY ENCLOSED FAN COOLED**  
**DEGREES OF PROTECTION IP55**  
**DUST & WATER JET PROOF**

**CUSTOMER** \_\_\_\_\_  
**USER** \_\_\_\_\_  
**FOR** \_\_\_\_\_  
**CUSTOMER'S ORDER NO.** \_\_\_\_\_  
**QUANTITY** \_\_\_\_\_  
**MFG. ORDER NO.** \_\_\_\_\_

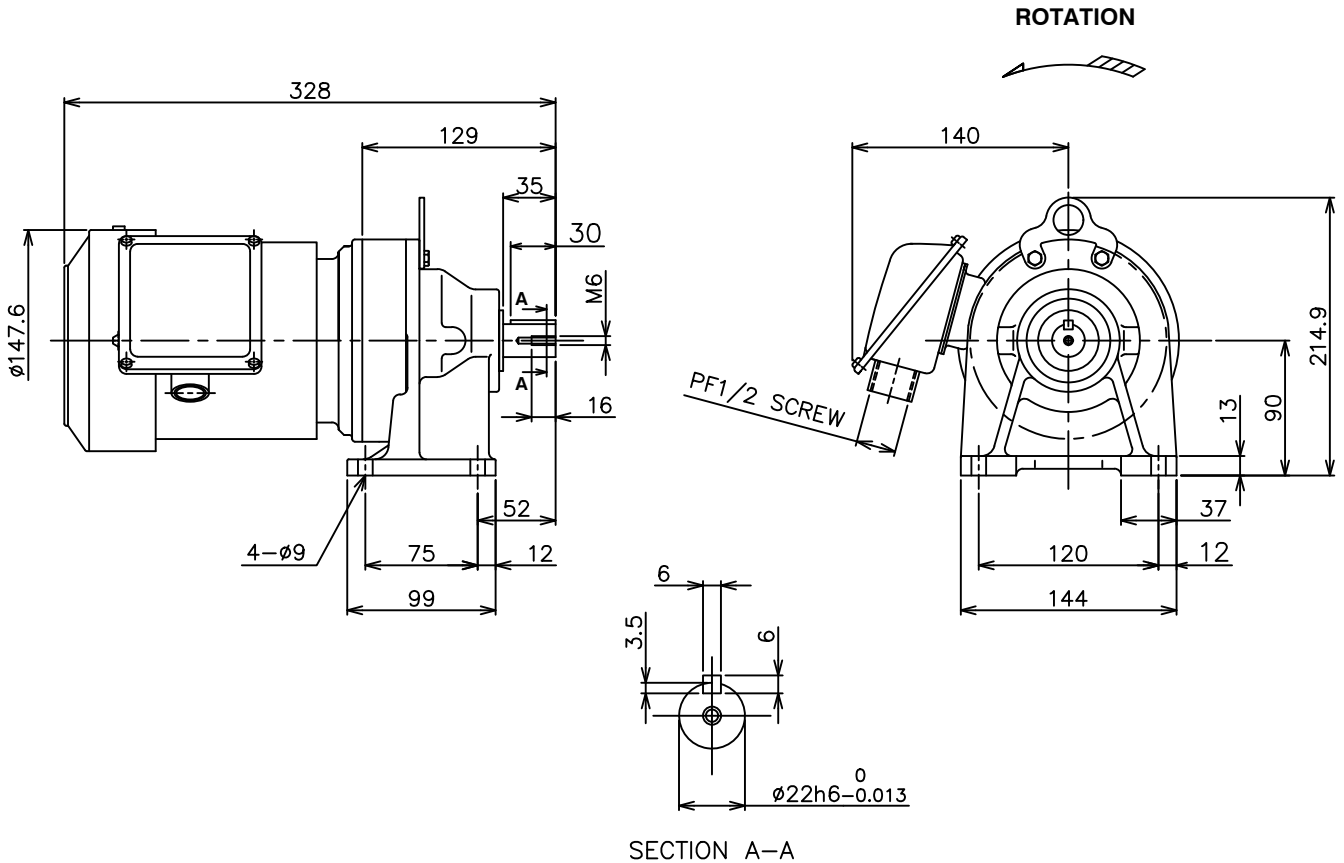

YOUR ORDER	MOTOR FRAME SIZE	RATING	TH. CLASS	AMB. TEMP	BEARINGS		COLOR	DIRECTION OF ROTATION	NO. OF LEAD WIRES	REMARKS
					LOAD SIDE	OPP. SIDE				
	71M	S1 (CONT.)	155(F)	40°C	6202ZZ	6201ZZ	GRAY (MUNSELL N5.5)	CCW	6	

YOUR ORDER	MODEL NAME	RATIO	SERVICE FACTOR	MOTOR OUTPUT		POLE	HERTZ	VOLT	OUTPUT SPEED (rpm)	LUBRICATION TYPE	WEIGHT (kg)
				HP	KW						
	CNHM05-6080-6	1:6	1.48	1/2	0.4	4	50 60	220/380/415 220/440	242 292	GREASE <sup>(1)</sup>	12
	CNHM05-6080-11	1:11	1.48	1/2	0.4	4	50 60	220/380/415 220/440	132 159		
	CNHM05-6080-15	1:15	1.48	1/2	0.4	4	50 60	220/380/415 220/440	97 117		
	CNHM05-6080-17	1:17	1.48	1/2	0.4	4	50 60	220/380/415 220/440	85 103		
	CNHM05-6085-21	1:21	1.38	1/2	0.4	4	50 60	220/380/415 220/440	69 83		

NOTE : (1) Grease had been filled from manufacturer already.

**MITSUBISHI ELECTRIC AUTOMATION (THAILAND) CO., LTD.**

		OUTLINE DRAWING NO.	REV.
	DIMENSION IN mm.		
		<b>0 M M 7 4 0 9 6 5</b>	<b>*</b>